

CmStick/T



Article-No:

1001-03-230

Description

The CmStick/T is the heart of the CodeMeter Digital Rights Management system as USB device in a very small and noble metal case. It contains a smart card chip including a secure memory of about 384 kbyte available for storing thousands of licenses. The basic idea of the revolutionary CodeMeter concept is that licenses can be stored for many products even from many different vendors at the same time. The CmStick/T contains a high accurate real time clock (RTC). With the embedded battery, the power-off time is bridged. When the CodeMeter Stick is plugged in, the RTC is used to synchronize the CodeMeter System Time to the future. The advantage of the smart card chip internal clock is combined with the RTC. If the battery is tampered or fails, the time handling still works like in a standard CmStick.

The minimum set of License Options includes: Text (description of an entry), Unit Counter (number of runs or actually run time of a license), Activation Time (time the license is valid from), Expiration Time (time the license is valid until), Usage Period (starts at first time), Maintenance Period (according to release date), Feature Map (up to 32 modules or versions), License Quantity (concurrent use / floating network licenses), Protected Data / Extended Protected Data (128x256 bytes read-only data), Hidden Data (128x256 bytes only readable with password; usable as secret/private key), Secret Data (128x256 bytes non-readable, only usable as secret/private key), User Data (256 bytes, unsecured), Customer Owned License Information (256 bytes).

Encryption algorithms used in firmware 4.10 with serial number 3-3440000 or higher: 128 and 256-bit AES, SHA-256, 1024, 2048, and 4096-bit RSA, 224-bit ECC.

The used smart card chip fulfills EAL 5+ (Common Criteria certified) and contains a random number generator. The CmStick/T has a green and a red LED.

Technical Specifications

The CodeMeter technology is covered by US 7.145.297 and other patents.

- Interface: Hi-Speed USB 2.0 certified, USB 1.1 compatible, Mass Storage Communication (MSC) or Human Interface Device (HID), HID default
- CodeMeter License memory:
 - Data retention: 10 years at room temperature
 - Data endurance:
 - Unit Counter: up to 500 million decrements
 - Other license parameter: up to 10 million updates to one license
- Power supply: 5 V bus-powered, < 20 mA (LEDs off), < 60 mA (both LEDs on)
- Temperature: -25°C...+85°C, non-condensing
- MTBF (Mean Time Between Failures): > 3 Million hours
- Real Time Clock inaccuracy: < ±1 minute/month @25°C
- Battery lifetime: 36 months from date of delivery

- Case/Dimensions: Noble metal case, 8 mm x 16 mm x 56 mm, Stick with protective metal cap: 8 mm x 16 mm x 61.5 mm
- Weight: 19 g, metal cap 5 g
- Warranty: 36 months

Certificates

The CmStick/T is tested and qualified with the following standards:

CE-Conformity | European Certificates

CmStick is fully compliant with all applicable European regulations.

- 2014/30/EU EMC: Report Bureau Veritas File CE180718D10, 2018-08-15
 - EN55022:2010/AC:2016, IEC/CISPR 32:2015, class B
 - EN55024:2010+A1:2015, IEC/CISPR 24:2010+AMD1:2015
 - EN55032:2015, AS/NZS IEC/CISPR 32:2015
- All CmStick/T are fully compliant according to EU Directives 2011/65/EU (RoHS), 2015/863/EU (RoHS amendment), SJ/T 11363-2014 (China RoHS2), 2012/19/EU (WEEE), 1907/2006/EC (REACH), 207/2011/EU (PFOS -REACH Annex XVII), 1272/2013/EU (PAH-REACH Annex XVII), and 1272/2013/EU (DINP-REACH Annex XVII).

International Certificates

- 47 CFR FCC, Part 15, Subpart B (2017), class B: Report Bureau Veritas File FD180718D10
- VCCI Class B ITE: Acceptance No. 2018048608, 2018-09-19
- KCC (South Korea): MSIP-REM-XWK-1001-03-XYZ, 2016-02-05
- BSMI (Taiwan): D43250 RoHS,
- ACMA (RCM): RCM20180091804-C, 2018-09-19

Other Certificates

- VDE License No. 129382
- C-UL-US listed I.T.E. Accessory 10 WB, E-File 211202

The encryption device is only for use with UL Listed PCs (low power system). Meets UL 60950-1 and CSA C22.2 No. 60950-1 Safety of Information Technology Equipment.

Ordering Information

P/N 1001-03-230: CmStick/T bulk

P/N 3640-01: Metal cap

Variants with individual cases, colors or labels on request.

RoHS compliant
WEEE-Reg-No:
DE 90465365



WIBU-SYSTEMS AG
Rueppurrer Strasse 52-54
D-76137 Karlsruhe
Tel: +49-721-93172-0
Fax: +49-721-93172-22
info@wibu.com
www.wibu.com

Technical Drawing

Article-No:

1 0 0 1 - 0 3 - 2 3 0

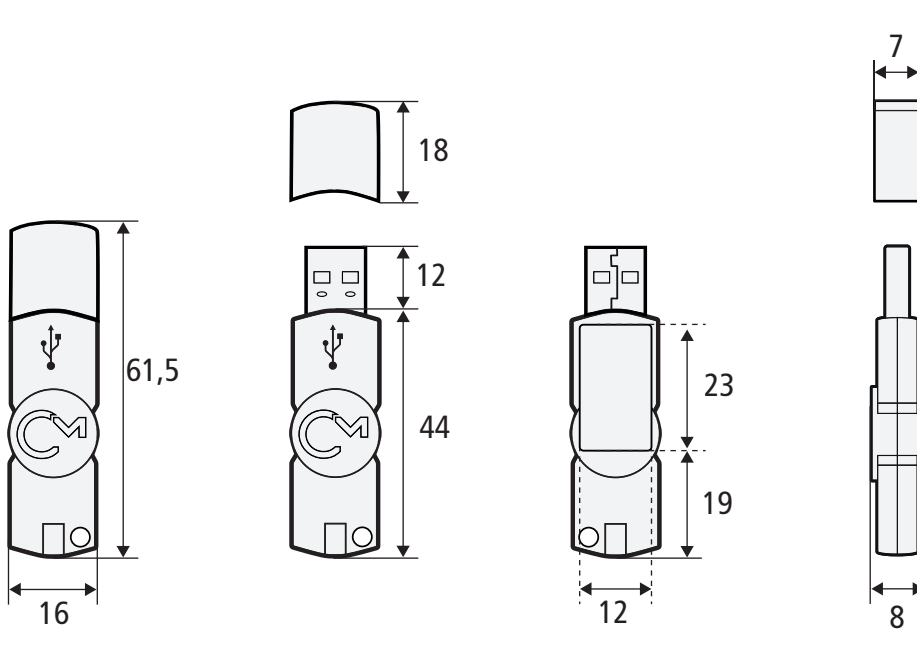

All dimensions in millimeter. Subject to change without notice.

WIBU-SYSTEMS AG
Rueppurrer Strasse 52-54
D-76137 Karlsruhe
Tel: +49-721-93172-0
Fax: +49-721-93172-22
info@wibu.com
www.wibu.com